



MULTI-ATTEMPT AUTOMATIC ENGINE CONTROL MODULE

Model No: AECM105

PREFACE	AECM105	IP67 rated
<p>The Model AECM105 is a new generation of AECM designed to automatically / remotely and manually start and stop the engine either by using the remote wired start-stop switch (default function) or via other optional devices: 24/7 digital weekly programmable timer built-in, wireless key fob control or/and Battery Voltage Sensor. The wireless key fob control allows the customer to start and stop the engine remotely within approximately 100m radius. The actual working distance depends on many factors and could be much less than 100m for instance if the key fob is used inside the building. The Battery Voltage Sensor (BVS) controls the engine starting battery voltage and able to start the engine automatically upon registering Low Voltage Threshold 11.8Vdc (this LVT can be re-adjusted by customer). It will continue to run the engine until the engine starting battery becomes fully charged at 13.8Vdc. The BVS will then register the High Voltage Threshold 13.8Vdc and shut down the engine (this HVT can be also re-adjusted by customer).</p> <p>AECM105 will indicate the operational status and fault conditions, automatically shut down the engine and indicate the start engine failure by flashing "START FAIL" LED on the front panel. Other faults are indicated by steady LED. Remote wired operation of the module is possible via single pole normally open maintained switch connected between terminal #5 (wire 1) and battery negative terminal #13 (wire GR/Y). The switch is shown on wiring diagram as "RST"</p>		

IMPORTANT!

THIS CONTROL MODULE MUST NOT BE CONNECTED DIRECTLY TO STARTER MOTOR, FUEL SOLENOID, LOAD CONTACTOR OR A GLOW PLUG. APPROPRIATELY RATED EXTERNAL POWER RELAYS SHOULD BE USED AS IT IS SHOWN ON THE DIAGRAM PROVIDED. The starter relay R1 can only energize for 2nd and 3rd crank cycle if "Low Oil Pressure" is sensed, to confirm that the engine is stationary. This is designed to prevent damage to the starter and ring gear in the event of the control module not sensing that the engine has started (i.e. terminals 15 and 16 are not connected to the alternator AC output). Should the engine still fail to start after the maximum number of attempts, "START FAIL" LED is displayed and the starter is latched out.

AECM105 numbered cable	DEFAULT SETTING
1. Remote wired start/stop input	N/O maintained switch (RST)
2. Starter motor relay output	Batt. pos. output
3. Oil pressure switch input	N/C (if engine is not running)
4. Emergency stop button switch input	N/O type
5. Fuel solenoid relay output	Batt. pos. output
6. Engine temperature switch input	N/O type
7. Battery positive power supply (+)	12Vdc / 24Vdc (6...40Vdc)
GR/Y. Battery negative power supply (-)	Common wire (Green/Yellow)
9. Glow plug relay output (optional)	Batt. pos. output
10. Load control relay output (optional)	Batt. pos. output
11. Generator live input (L)	100~300Vac
8. Generator neutral input (N)	100~300Vac

The relays supply positive plant supply out (EXCLUDING LOAD CONTROL RELAY ~100-300VAC!)

AECM105 specification

DC Supply: generator battery 12V or 24V (6...40Vdc)
Max. standby current: 10mA @12Vdc
AC voltage input max: 300Vac
Under speed S/D @ 30Hz (45Hz for USA and Canada)
Over speed S/D @ 57Hz (69Hz for USA and Canada)
Number of attempts: 3 (user-configurable prior to order)
Crank duration: 12sec (automatically regulated via sensing AC alt.)
Pre-heat time: 10 sec (user-configurable prior to order)

Load On/Off delay: 10 sec (user-configurable prior to order)
Hold-off time*: 7sec (user-configurable prior to order)
Starter / Fuel / Glow / Load relay output: 10A max
Dimensions: 158x90x65mm
Operating temperature range: -30 to +70°C
Humidity Range Operating: 20-80%
Enclosure IP code: IP67 (weatherproof type)



MULTI-ATTEMPT AUTOMATIC ENGINE CONTROL MODULE

Model No: AECM105

Description	
WIRED REMOTE / LOCAL CONTROL	
<p><i>Toggle switch RST is On (closed).</i> 0.5 second after the fuel relay R2 is energized, the 3 attempt start will begin its start sequence: the start relay R1 will energize, feeding battery +ve on terminal #14 (wire 7) to terminal #1 (wire 2) and thence on to the start circuit (external power relay PR1). The crank period is set for 12 seconds. If the engine has not fired by the end of 1st attempt, the starter is turned off for a 20 sec. period. The sequence will then repeat up to a maximum number of start attempts. Following a successful start, sensed when AC alternator's voltage rises above 40% of nominal (terminals #15 (wire 8) and #16 (wire 11), the crank relay is de-energized and latched out to prevent re-engagement of the starter with the engine running.</p>	
PRE-HEAT CONTROL (optional function) Make sure that "pre-heat" DIP switch 1 is "ON"	
<p>When pre-heating cycle is timed out and flashing LED (HET/GL) on the panel is turned off, the fuel relay R2 is energized and the 3 attempt start will begin its start sequence: the start relay R1 will energize, feeding battery +ve on terminal #14 (wire 7) to terminal #1 (wire 2) and thence on to the start circuit (external power relay PR1). The crank period is set for 12 seconds. If the engine has not fired by the end of 1st attempt, the starter is turned off for a 20 sec. period. The sequence will then repeat up to a maximum number of start attempts. Following a successful start, sensed when AC alternator's voltage rises above 40% of nominal (terminals #15 (wire 8) and #16 (wire 11), the crank relay is de-energized and latched out to prevent re-engagement of the starter with the engine running.</p>	
LOAD CONTROL (optional function)	WIRELESS CONTROL (optional function)
<p>After a successful start, when engine's parameters are settled (when 7 sec time delay provided by hold-off timer is timed out, then warm-up time delay is timed out), the Load Control Output (relay R4) will energize (ON LOAD LED will lit) and send a signal from terminal #4 (wire 10) to an external customer's contactor which will connect the AC alternator output to the load. The warm-up time before accepting load and cool-down time after relieving load (while generator is still running and is ready to accept the load again if the remote/local start signal is switched back on) are re-programmable (by us) with a limit of 255 sec [4.25 min] max. (for each timer). Please contact us first if specific time settings are required. Otherwise the module will have 10 sec warm-up/cool-down time delays.</p>	<p><i>Toggle switch RST is Off</i></p> <p>Make sure there are no metal doors/walls/other metal shields between you and AECM105 module. Any metal or brick wall may significantly reduce the working distance between the transmitter (key fob) and AECM105 module.</p> <p>Press "A" button on a key fob for 1 sec and release it. The generator should try to start within a few seconds.</p> <p>Press "B" button to stop. If unsuccessful - come closer to the module.</p>
LOAD CONTROL SETTINGS:	<i>Wireless transmitter/receiver specification</i>
10 SEC WARM-UP 10 SEC COOL-DOWN	<p>Receiver: internally fitted pcb. Transmitter/Receiver working frequency: 315Mhz (433Mhz optional) Number of channels: 2 Encoding type: fixed code</p>
RELAY OUTPUTS ARE PROVIDED FOR:	CONFIGURABLE INPUTS ARE AVAILABLE FOR:
<ul style="list-style-type: none"> • Starter Motor Output R1 • Fuel Solenoid Output R2 • Glow Plug Output R3 • Load Control Output R4 	<ul style="list-style-type: none"> • Wired remote start/stop • High engine temperature • Oil pressure • Emergency stop • AC alternator monitor
MULTIPLE ALARM CHANNELS ARE PROVIDED TO MONITOR THE FOLLOWING:	
<ul style="list-style-type: none"> • Under/Over speed S/D (speed fault). This alarm sensor can be enabled/disabled via SPEED DIP switch 2. • Low oil pressure S/D. "LOW OIL" led is lit when fault is identified. • High engine temperature S/D. "HET/GL" led is lit when fault is identified. • Fail to start S/D. "ST.FAIL" led is lit when fault is identified. • Emergency stop S/D. E. STOP led is lit when fault is identified. 	
<p><i>* During engine cranking and for a short time afterwards the protective hold-off timer is active and the relevant alarms inputs are inhibited. This enables the engine to start and achieve normal running conditions. Once the timer has expired, the inputs are enabled providing normal protection from the module.</i></p>	



MULTI-ATTEMPT AUTOMATIC ENGINE CONTROL MODULE

Model No: **AECM105**

WIRING DIAGRAM

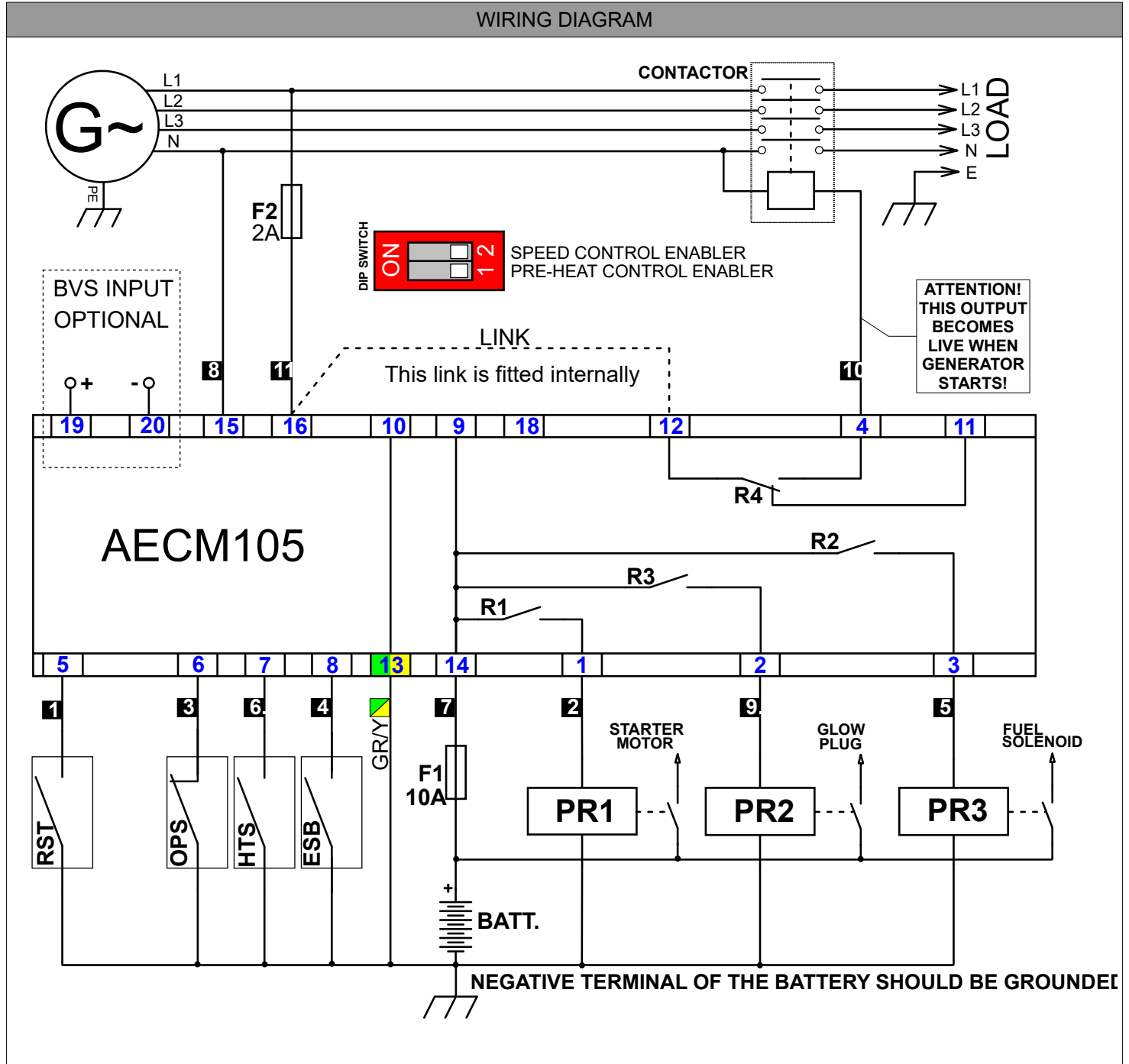



MULTI-ATTEMPT AUTOMATIC ENGINE CONTROL MODULE

Model No: AECM105

DIMENSIONS

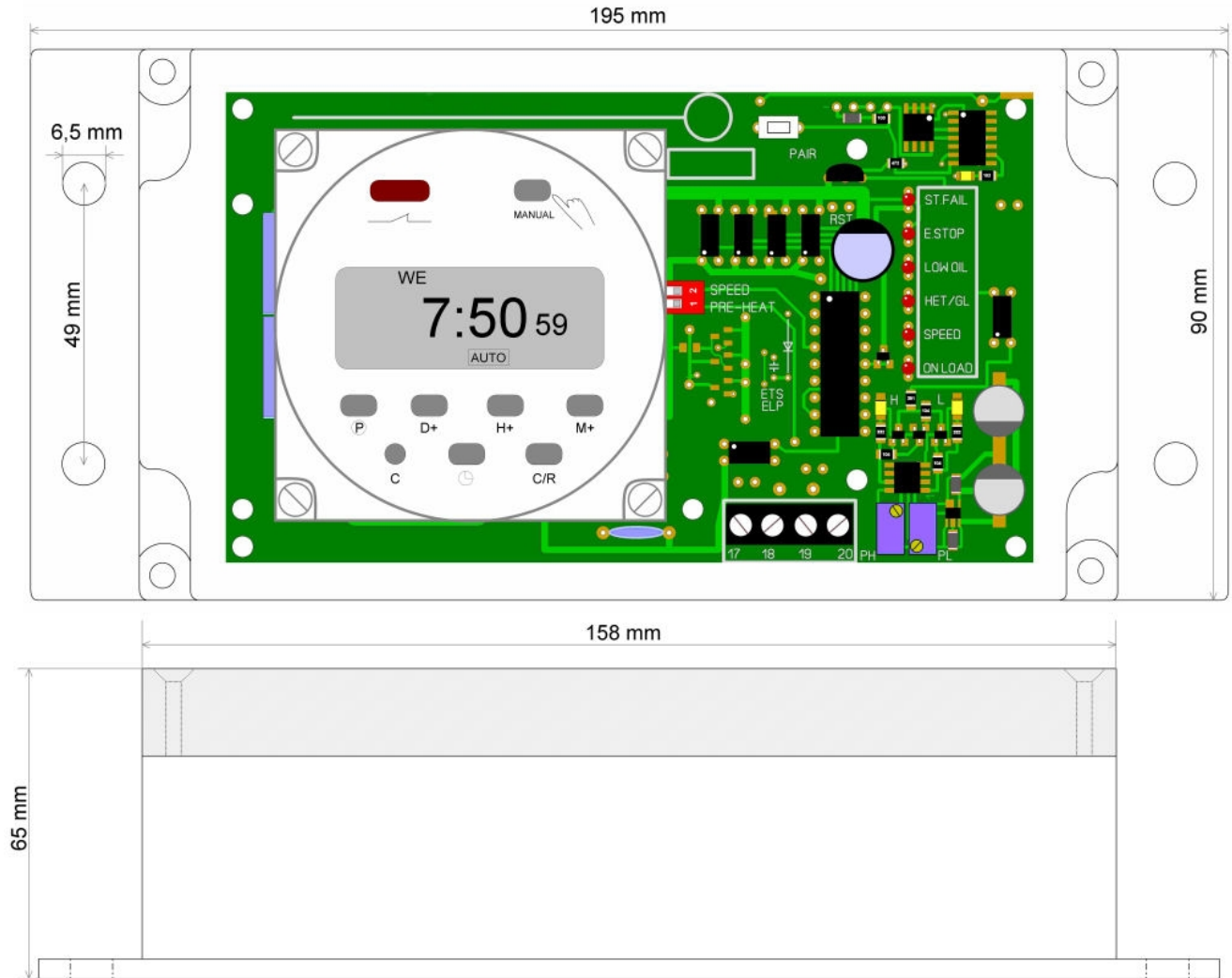



BVS (BATTERY VOLTAGE SENSOR) (optional function)

IMPORTANT NOTES!

BVS Sensor Is Disabled By Default. Fit The Configurable Link (Shown Below) To Enable.
Your BVS is set to monitor the engine starting battery.
To re-configure BVS for sensing an external battery bank please contact us before purchase.

The BVS (Battery Voltage Sensor) allows the AECM (Automatic Engine Control Module) to start and run the engine automatically when your engine starting battery is ready to be charged. The BVS monitors two voltage thresholds: Low Voltage Threshold (LVT) and High Voltage Threshold (HVT). When controlled voltage becomes equal to LVT the BVS tells the AECM to start and run the engine until it measures the HVT.

Please note that BVS usually controls the engine starting battery voltage which is also a power supply to the AECM105. Should you wish to control an independent battery (not an engine starting battery!) please contact us prior to order for a quote. In this case terminals #19 and #20 become available for you. The BVS input is designed to control DC voltage from 6Vdc to 30Vdc max. and we can pre-set your specific voltage HVT and LVT for you.

This BVS enabled control module comes with following BVS thresholds:

Start the engine @ 11.8 Vdc
Stop the engine @ 13.8 Vdc

Please note: you can always re-calibrate these thresholds on-site.

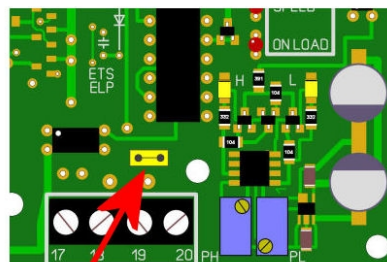
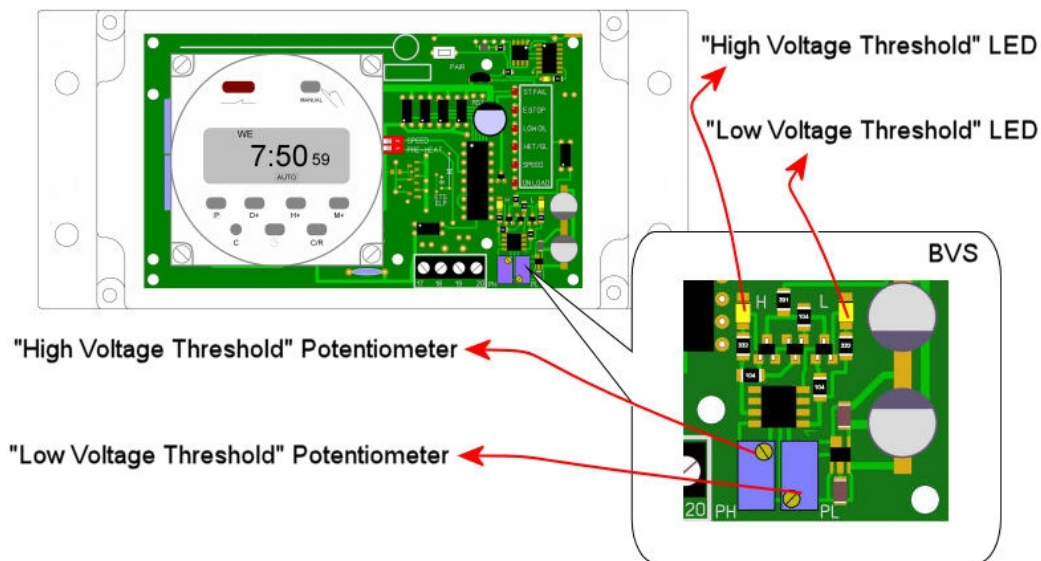

**REMOVE THIS LINK
IF BVS IS NOT REQUIRED**

You may receive this configuration BVS link not fitted. Please fit it when required.
Make sure your starting battery voltage is above 13.8V. Otherwise the generator may start immediately when link fitted.

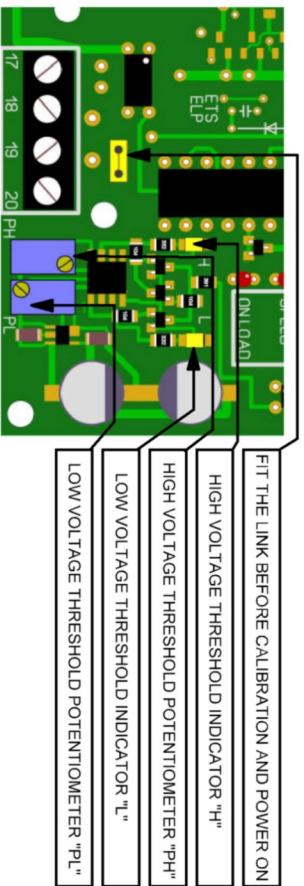

It is advisable to use an adjustable DC power supply unit (0V to 30V adjustable voltage output), instead of real battery to speed up the process of calibration.

NOTE

HOW TO SET UP THE BVS LOW THRESHOLD

Disable AECM105 by applying Emergency Stop Button "ESB".

This prevents the engine from accidental start up during calibration process of BVS.

Connect your discharged (ready to be charged) engine starting battery to terminals #13 (wire GR/Y) and #14 (wire T). Start turning "PL" (very slowly) clockwise/anticlockwise* until LED "L" changes its state from OFF to ON. Stop turning immediately when you notice this change.

HOW TO SET UP THE BVS HIGH THRESHOLD

Connect your fully charged engine starting battery to terminals #13 (wire GR/Y) and #14 (wire T).

Start turning "PH" (very slowly) clockwise/anticlockwise* until LED "H" changes its state from ON to OFF. Stop turning immediately when you notice this change.

Enable AECM105 by switching off Emergency Stop Button.

*Note: the direction of turning depends on previous threshold settings and is usually clockwise, however sometimes it needs to turn anti-clockwise.

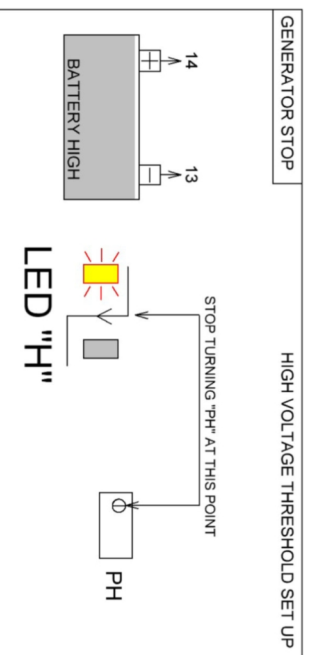
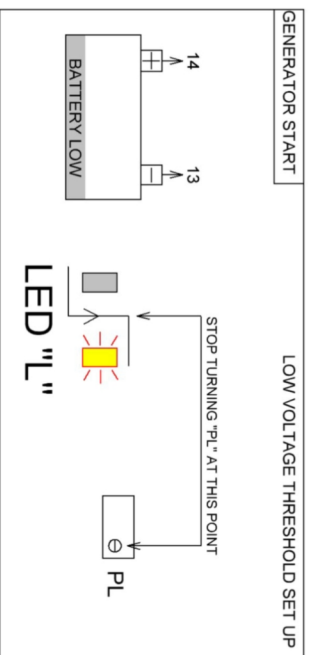

Q1: Which way do I need to turn the pot?

A: To increase your high voltage threshold- turn the pot "PH" anticlockwise. To increase your low voltage threshold- turn the pot "PL" clockwise.

For instance: your current low voltage threshold is 11.8Vdc. You would like to change it to 12.5Vdc. Discharge your battery down to 12.5Vdc. disable AECM via Emergency Stop Button, connect your battery to terminals 13 and 14 (wires #GR/Y and #T), start turning "PL" clockwise until you see the LED "L" switched On, stop turning "PL" immediately when you notice this change. Enable AECM via Emergency Stop Button.

Q2: How many turns these potentiometers have?
A: Up to 30 turns.