

3 Attempt Automatic Generator Control Module

AECM104FKS

DESCRIPTION

The Model AECM104FKS is an Automatic Generator Control Module designed to automatically [remotely] or manually start and stop the engine. It will indicate the operational status and fault conditions, automatically shut down the engine and indicate the start engine failure by flashing "START FAIL" LED on the front panel. Other faults are indicated by steady LED. Operation of the module is via 3 pos. key switch mounted on the front panel with STOP-AUTO-RUN positions. Remote control of the module is via terminal 1 (maintained N/O switch).

Relay outputs are provided for:

- Fuel Solenoid Output
 - Starter Motor Output
 - Load Control Output [optional]
 - Preheat Output [optional]
- This output can be enabled / disabled via DIP switch 1

The relays supply positive plant supply out.

START

0.5 Second after the fuel relay is energized the 3 attempt start will begin its start sequence: the start relay will energize, feeding battery +ve on terminal 7 to terminal 2 and thence on to the start circuit. If the engine has not fired by the end of 1st attempt, the starter is turned off for a resting period. The sequence will then repeat up to a maximum number of start attempts. Following a successful start, sensed when AC alternator's voltage rises above 40% of nominal, the start relay is de-energized and latched out to prevent reengagement of the starter with the engine running.

Configurable inputs are available for:

- Low Oil Pressure.
- High Engine Temperature.
- Remote Start.
- AC alternator monitor.
- Emergency Stop input [N/O] to give protection expansion.

Multiple alarm channels are provided to monitor the following:

- Under/Over speed (speed fault)
This sensor can be enabled / disabled via DIP switch 2
- Low oil pressure
- High engine temperature
- Fail to Start
- Spare Alarm Channel [emergency stop]

PRE-HEAT & START (optional)

DIP switch 1 is "ON"

When 10 second pre-heating cycle is timed out and flashing LED on the panel is turned off, the module will begin its start sequence: the fuel solenoid relay is energized feeding battery +ve on terminal 7 to terminal 5 and thence to the fuel solenoid circuit, the start relay will energize, feeding battery +ve on terminal 7 to terminal 2 and thence on to the start circuit. If the engine has not fired by the end of 1st attempt, the starter is turned off for a resting period. The sequence will then repeat up to a maximum number of start attempts. Following a successful start, sensed when AC alternator's voltage rises above 40% of nominal, the crank relay is de-energized and latched out to prevent reengagement of the starter with the engine running.

The AECM104 series modules have been designed for front panel mounting. The module is fitted into the 68X68mm cut-out with the fixing clips removed. These are then fitted from the rear.

SPECIFICATION [default settings]

DC Supply: generator battery 12 / 24Vdc
Max. Standby Current: 10 mA @ 12 Vdc
Alternator Input Range: 300 VAC max
Under speed shutdown: @ 30 Hz [45Hz for USA and Canada]
Over speed shutdown: @ 57 Hz [69Hz for USA and Canada]
Number of attempts: 3 (up to 10 can be programmed)
Crank duration: 12 sec
Preheat time: 10 sec
Load on time delay: 10 sec
Load off time delay: 10 sec
Hold-off timer set for: 7 sec
Starter relay output: 3.0A max
Fuel solenoid output 3.0A max
Glow plug relay output: 3.0A max
Load control relay output: 3.0A max
Dimensions: 72 X 72 X 60mm
Operating Temperature Range: -30 to +70°C.

LOAD CONTROL (optional)

After a successful start, when engine's parameters are settled (when 7 sec time delay provided by hold-off timer is timed out), the Load Control Output will energize and send a signal from terminal 10 to an external power relay. This energizes a contactor which will connect the AC alternator output to the load. The run time before accepting load and the run time after relieving load (while generator is still running and is ready to accept the load again if the remote/local start signal is switched back on) are reprogrammable with a limit of 255 sec [4.25 min] max. (for each timer). Should the engine still fail to start after the maximum number of attempts, "START FAIL" LED is displayed and the starter is latched out until reset via "STOP" position of front switch or via terminal 1 if the engine start was initially made via remote start signal.

IMPORTANT!

**THIS CONTROL MODULE MUST NOT
BE CONNECTED DIRECTLY TO
STARTER MOTOR, FUEL SOLENOID, AC
CONTACTOR OR A GLOW PLUG.
APPROPRIATELY RATED EXTERNAL POWER RELAYS
SHOULD BE USED AS IT IS SHOWN ON THE DIAGRAM PROVIDED.**

The starter relay can only energize for 2nd and follow up crank cycle if "Low Oil Pressure" is sensed, to confirm that the engine is stationary. This is designed to prevent damage to the starter and ring gear in the event of the control module not sensing that the engine has started (i.e. terminals 11 and 12 are not connected to the alternator AC output).

WIRING DIAGRAM

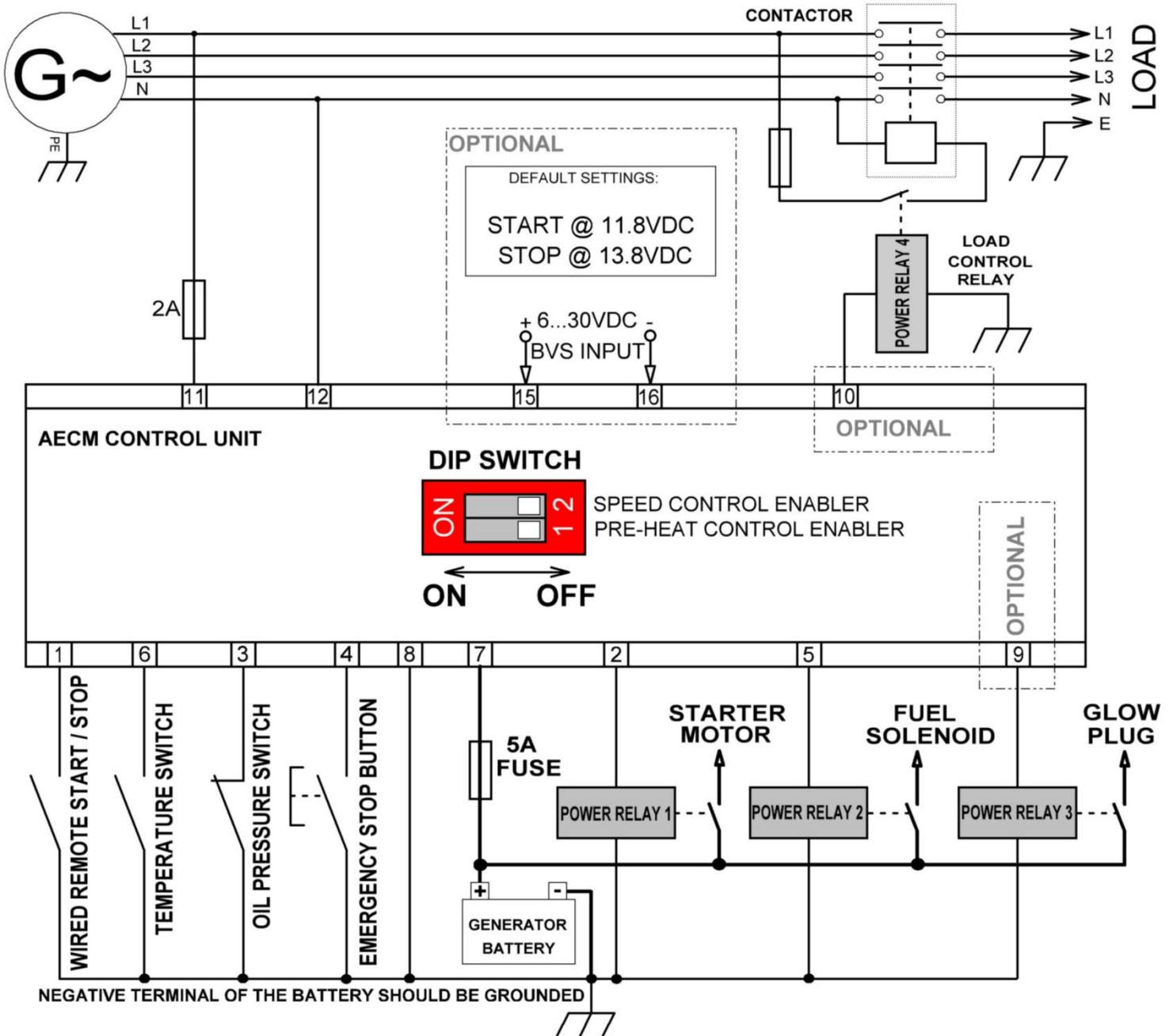

BVS set up (optional)

NOTE: YOUR BVS SET FOR START@11.8VDC AND STOP@13.8VDC

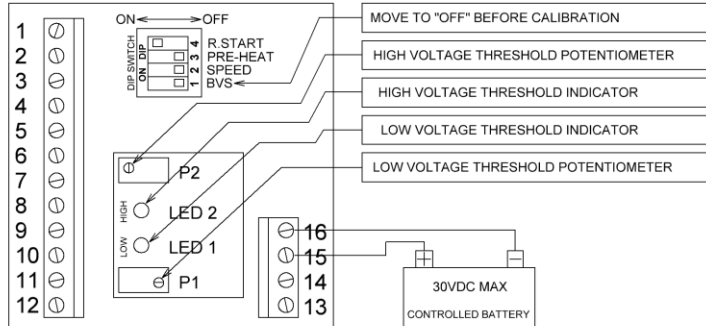

NOTE

It is advisable to use an adjustable DC power supply unit (0V to 30V adjustable voltage output), instead of real battery to speed up the process of calibration.

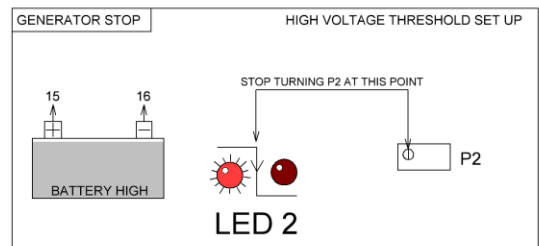
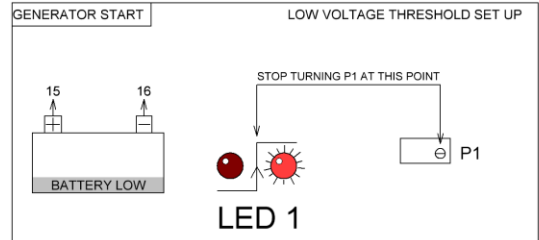

HOW TO SET UP THE BVS LOW THRESHOLD

1. Disable BVS via DIP switch 1 (move to Off position)
2. Connect your discharged (ready to be charged) battery to terminals 15 and 16
3. Start turning P1 (very slowly) and find the position when LED1 changes its state from Off to On
4. Stop turning immediately when you notice this change.

HOW TO SET UP THE BVS HIGH THRESHOLD

1. Disable BVS via DIP switch 1 (move to Off position)
2. Connect your fully charged battery to terminals 15 and 16
3. Start turning P2 (very slowly) until LED2 changes its state from On to Off
4. Stop turning immediately when you notice this change
5. Enable BVS via DIP switch 1 (move to On position).

Q1: Which way do I need to turn the pot?

A: To increase your high voltage threshold-turn the pot P2 anticlockwise.
 To increase your low voltage threshold-turn the pot P1 clockwise.

For instance: your current low voltage threshold is 11.8Vdc. You would like to change it to 12.5Vdc. Discharge your battery down to 12.5Vdc, disable BVS via DIP switch 1, connect your battery to terminals 15 and 16, start turning P1 clockwise until you see the LED1 switched On, stop turning P1 immediately when you notice this change. Enable BVS via DIP switch 1.

Q2: How many turns these potentiometers have?
 A: Up to 30 turns.

Wiring Diagram for the BVS enabled AECM

