



## Automatic Transfer Switch

## ATS105SP

### Description

The configurable Automatic Transfer Switch Model ATS105SP allows many of the industry's demanding specifications to be achieved. The ATS105SP is used to start a generator on a mains outage, sending a signal to the Auto Start Enabled Generator and transfers the load when engine's operating criteria has been met. The engine's warm-up time before accepting load and cool-down time after relieving load can be set directly on the module using 4 pole DIP switch located on the back plate. The ATS105SP allows working on 3 phase and single phase mains/generator supply. Each phase is monitored individually.

### How it works

Under normal circumstances when mains power is available, National Grid power supply runs through the Automatic Transfer Switch (ATS) contactors and connects to your distribution board. When mains power fails, the ATS will pause for a 25 sec. period to ensure you haven't had a power spike. ATS will then initiate a generator start signal (by closing terminals 3 and 4), warm up the generator within preset time set by **internal programmable timer\*** (see table A below) and then connect the generator power supply to your home or business premises. Upon mains power being restored and stays healthy for more than 25 sec. the reverse happens and the controller automatically transfers load from the generator power back to mains shutting down the generator after a cool-down period (cool-down period = warm-up period) and restoring it to standby mode. The ATS105SP series modules have been designed for front panel mounting. The module is fitted into the cut-out (68X68mm) with the fixing clips removed. These are then fitted from the rear.

Table A			
DIP switch combinations / delay time (sec)			
8	15	25	32
50	55	70	95
120	140	165	190
210	235	260	280



BUTTON "TEST"



### Specification

DC Supply: 6...40VDC  
Max. Operating Current: 80 mA at 12V  
Max. Standby Current: 10 mA at 12 V  
Alternator/Mains Input Range: 100 - 300 V AC  
Frequencies supported: 50Hz and 60Hz  
Mains/Generator Contactor Relay output: 10 Amp at 250V AC  
Generator Start Volt Free Relay output: 2 Amp. At 28V DC  
Dimensions: 72 X 72 X 60mm  
Operating Temperature Range: -30 to +70°C  
2 X side clamps for secure panel fixing included.

Button TEST is designed to simulate a mains outage condition. Once activated, the ATS105SP control module will pause for 25 sec. to make sure the mains is not returning back and then initiate an isolation of the load from "unhealthy" mains, request a generator start up and automatic connection of the load with generator running after warm-up period set by internal timer is timed out.

### THREE PHASE CONNECTION

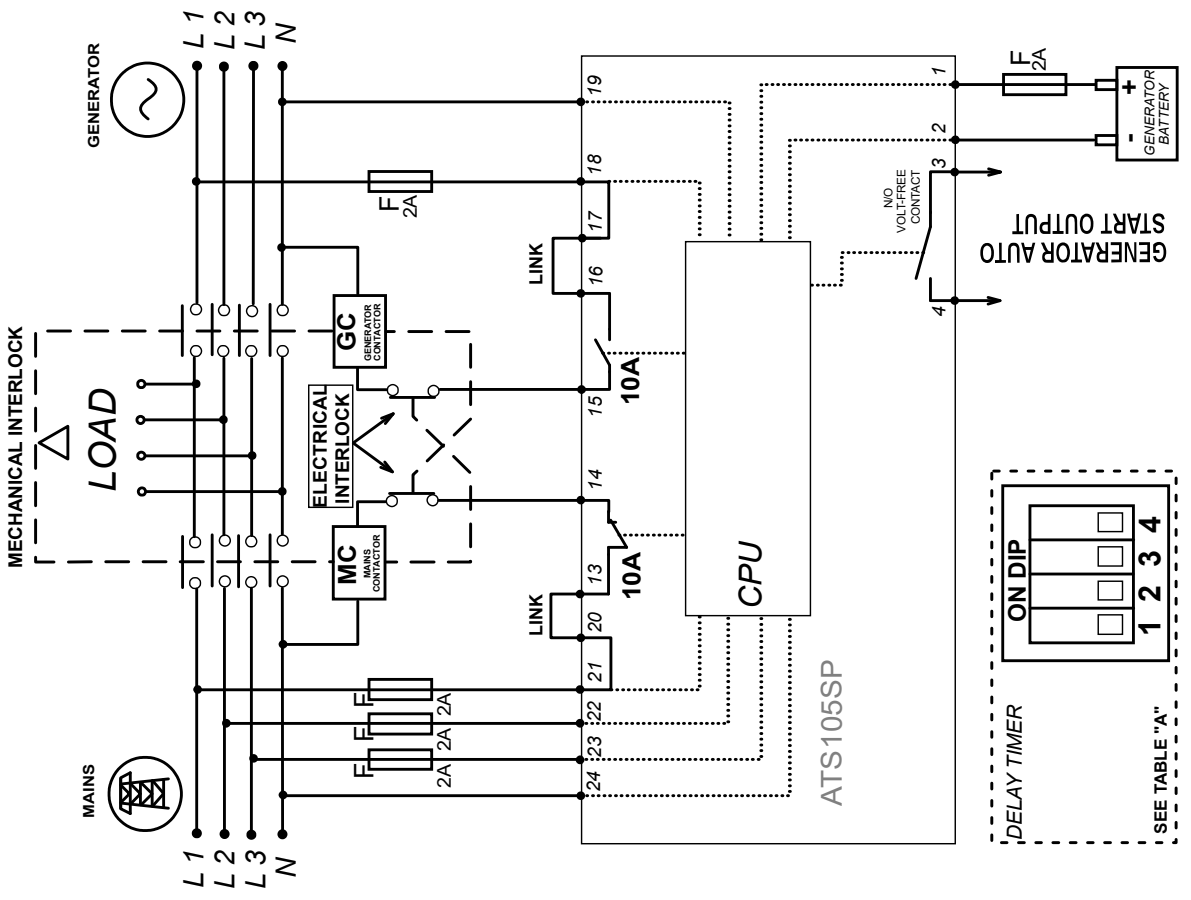

### SINGLE PHASE CONNECTION

