

Honda generator compatible auto start control module

Honda EM3800SX, EM4000SX, EM5000SX, EM6500SX, (EM4500CXS / EM5500CXS B,F,G,GW type), EM5000SXX2, EM6500CXS.

DESCRIPTION

The Model AECM103FBSL is an Automatic Engine Control Module (controller) designed to automatically or manually start and stop the Honda engine. The controller has 3 automatic starting attempts. Should the controller run out of starting attempts and the engine couldn't start, the controller will indicate this failure by intermittent sound. Any other unexpected engine shutdown is indicated by a continuous sound. To reset the controller back to working mode: turn the wired switch to Off position or, if the controller was initially started from the key fob: press button "B". Automatic wired operation of the module is via ordinary volt-free Off-On switch connected to the 2 pole spring wire quick connector. This wired connection can be also used to start an stop the engine from the ATS panel volt-free control switch. Remote wireless control of the module is via key fob buttons: "A" start and "B" stop. The key fob is an optional device and can be ordered from the "Extra Items/Features" section. The number of the key fobs can be selected during checkout. The key fob comes without battery fitted, please fit your own battery (type "23A").

AUTO START CONTROLLER CONNECTION

1. Remove the battery maintenance cover
2. Remove the plug from the 6-pin connector.

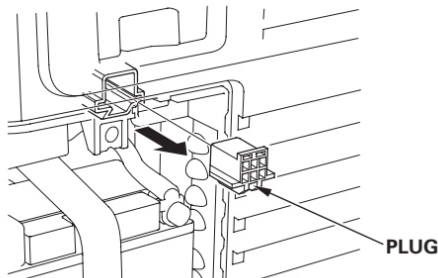

3. View the back of the maintenance cover and locate the knockout near the top center of the cover. Carefully remove the knockout.

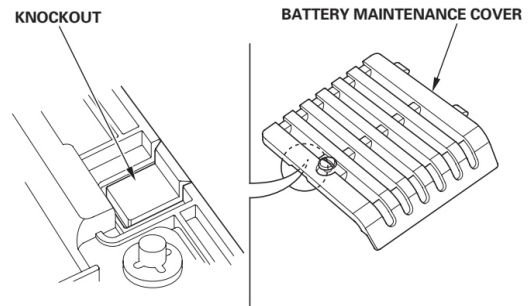

4. Pass the remote control cable through the battery maintenance cover knockout.
5. Plug the remote control cable into the 6-pin connector.
6. Connect the wire 1 ring terminal into the battery positive terminal.
7. Connect the remote control switch 2 core cable to the spring wire quick connector and pass it through the battery maintenance cover knockout.
8. Install the battery maintenance cover and tighten the cover screw.

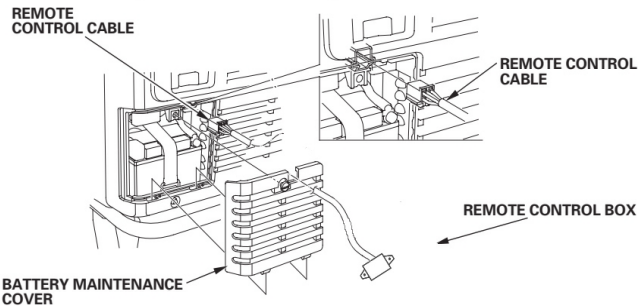

9. To avoid accidentally unplugging the remote control cable, secure the cable to the generator frame with a cable tie as shown.

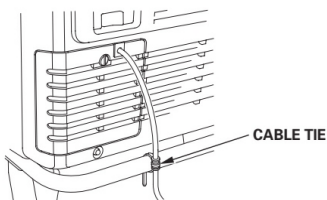

- Never operate the generator without the battery maintenance cover in place, as poor engine and generator performance will result.
- When the remote control is not being used, replace the plug on the connector.

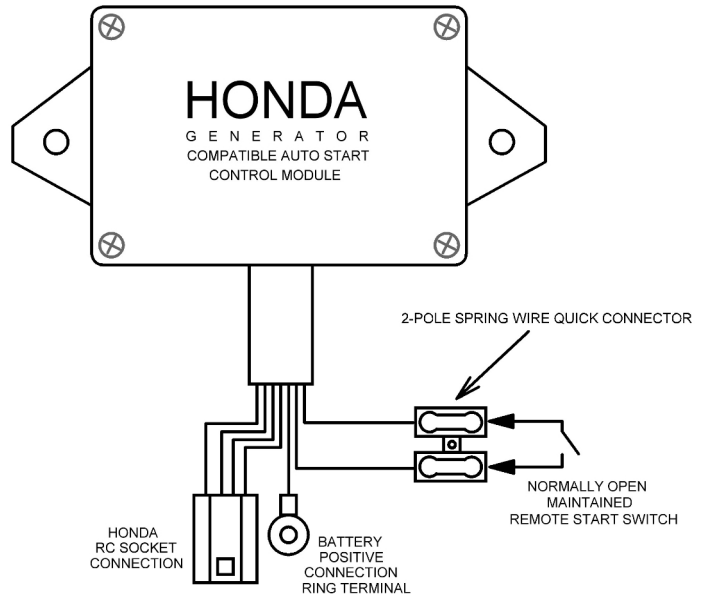
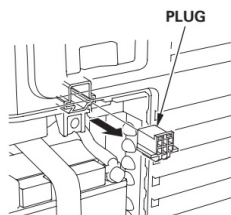

SPECIFICATION

DC Supply: 12 VDC (generator battery)
 Max. Standby Current: 9.8 mA @ 12 V
 Number of attempts: 3
 Pause between each automatic attempt: 10sec
 Crank duration: 5sec
 Dimensions: 85x58x33mm
 Length of cable: 2m
 Operating Temperature Range: -30 to +70°C.

Note: the controller can be re-configured to start the engine after 10sec delay. This function may be required when the controller is operated from the ATS panel automatically. 10 sec start delay is used in combination with an ATS panel to prevent multiple short start-stop commands coming from the ATS panel while the mains unstable during blackout. To set up 10sec start delay: open the controller cover and locate the red dip switch (S-DELAY). Use your finger to move the dip switch 1 to ON position, then replace the cover and tighten screws. In this mode the controller will produce an intermittent sound accompaniment prior to each starting attempt during 10sec delay.